

| Table de nomenclature |                               |                            |     |
|-----------------------|-------------------------------|----------------------------|-----|
| REP.                  | DESIGNATION (FR)              | DESIGNATION (ENGLISH)      | QTE |
| 1                     | VENTILATEUR DU DEPOUSSIEREUR  | DUST COLECTOR FAN          | 1   |
| 2                     | BOMBONNE DE DECOLMATAGE       | UNCLOGGING DEVICE          | 1   |
| 3                     | CARTOUCHE FILTRANTE           | FILTERING CARTRIDGE        | 1   |
| 4                     | CORPS VIDE SAC                | SACKTIP BODY               | 1   |
| 5                     | FILTRE REGULATEUR PNEUMATIQUE | PNEUMATIC REGULATOR FILTER | 1   |
| 6                     | SONDE DE NIVEAU               | LEVEL PRODE                | 1   |
| 7                     | SAUTERELLE A CROCHET          | CLAMP LEVER                | 2   |
| 8                     | PORTE VIDE SAC                | SACKTIP DOOR               | 1   |
| 9                     | COMPACTEUR DE SAC             | SACK COMPACTOR             | 1   |
| 10                    | TABLETTE                      | ERGONOMIC REMOVABLE        | 1   |
| 11                    | VIBREUR PNEUMATIQUE           | PNEUMATIC VIBRATOR         | 2   |
| 12                    | VANNE DE VIDANGE PRODUIT      | OUTLET PRODUCT VALVE       | 1   |

DIMENSION : [inch] / mm PLAN D'INFORMATION / INFORMATION DRAWING

PALAMATIC N'AYANT PAS EN CHARGE LE GENIE CIVIL, IL EST DE VOTRE RESPONSABILITE DE VOUS ASSURER DE LA RESISTANCE, DE LA STABILITE ET DE LA PLANEITE DE VOS SUPPORT OU SOLS RECEVANTS NOS EQUIPEMENTS, AUX DIFFERENTS EFFORTS ET CONTRAINTES AUQUELS ILS POURAIENT ETRE SOUMIS.

**CE PLAN EST LA PROPRIETE DE LA SOCIETE PALAMATIC - IL NE PEUT ETRE COPIE OU UTILISE SANS AUTORISATION**  
 THIS DRAWING IS THE PROPERTY OF THE COMPANY PALAMATIC - IT CANNOT BE COPIED OR USED WITHOUT AUTHORIZATION

CIVIL ENGINEERING WORKS ARE NOT INCLUDED IN PALAMATIC'S SCOPE OF SUPPLY. IT IS THE CLIENT'S RESPONSIBILITY TO ENSURE THE STABILITY, RESISTANCE AND FLATNESS OF THE STRUCTURES AND TERRAIN ON WHICH, PALAMATIC'S EQUIPMENT WILL BE MOUNTED. THESE STRUCTURES AND TERRAIN MUST BE ABLE TO WITHSTAND THE DIFFERENT LOADS AND CONSTRAINTS BROUGHT ON BY THESE EQUIPMENTS

Rue de l'Écolais 02 90 56 20 61  
 Z.A. de la Croix Rouge  
 35530 BRECE CYRIL.PICHARD@PALAMATIC.FR



|          |     |             |                   |     |                          |                          |            |
|----------|-----|-------------|-------------------|-----|--------------------------|--------------------------|------------|
| 20-03-19 |     | A           | DIFFUSION         | CYP | Format / Echelle / Scale | N° Plan / Drawing number | REV: A 1/3 |
| DATE     | REV | OBSERVATION | REVISER / REVISER | A3  | 1:15                     |                          |            |

Designation / Name : VIDE SAC DEPOUSSIEREUR  
 Description : SACKTIP SDEP 1200  
 Dessiné par / Drawn by : PICHARD  
 Ref. Dossier / Project reference :

# SACKTIP FERME / CLOSED

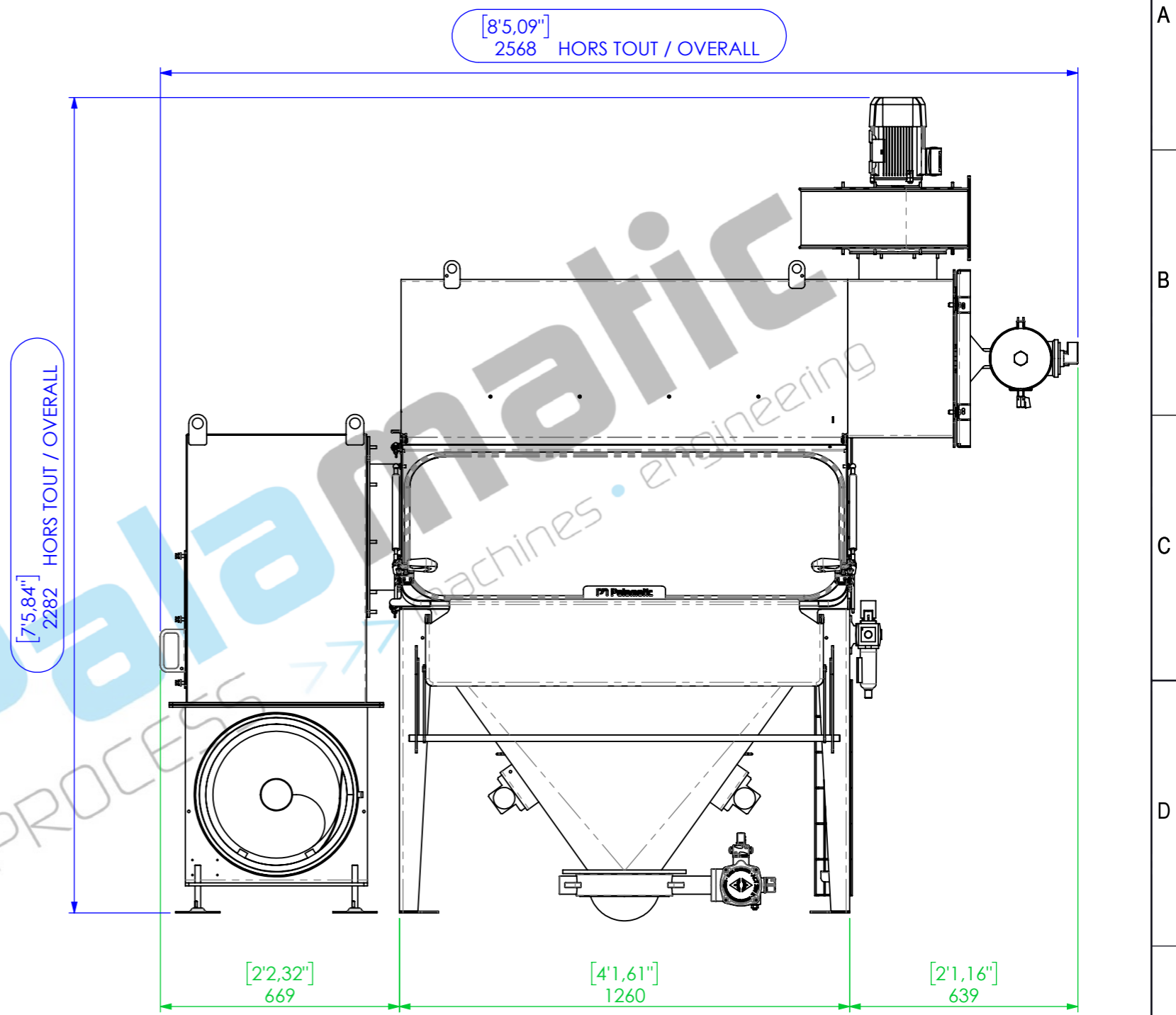
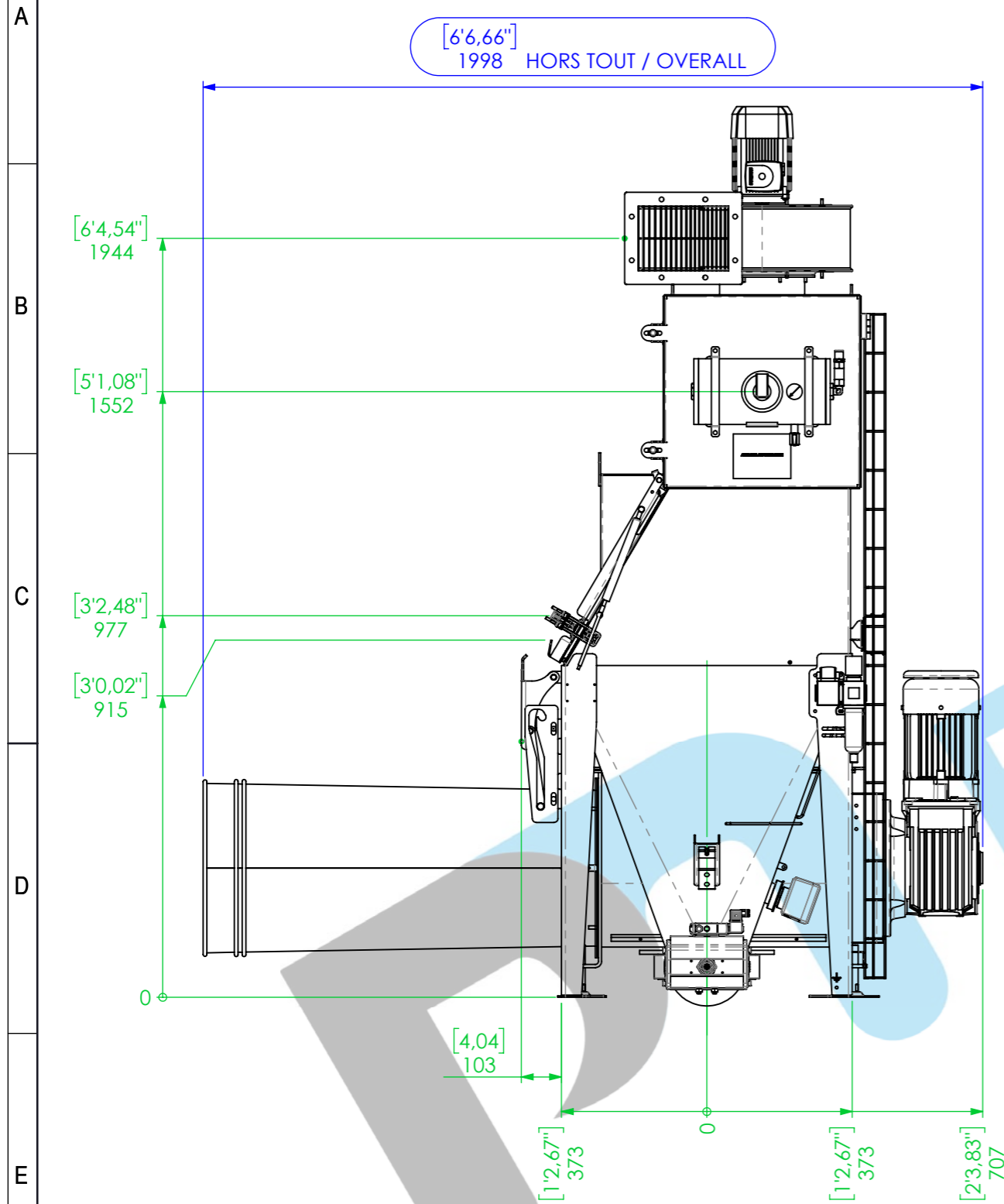

|  |     |   |                            |
|--|-----|---|----------------------------|
| DIMENSION : [inch]<br>mm   |     | PLAN D'INFORMATION / INFORMATION DRAWING  |                            |
| <p>PALAMATIC N'AYANT PAS EN CHARGE LE GENIE CIVIL, IL EST DE VOTRE RESPONSABILITE DE VOUS ASSURER DE LA RESISTANCE, DE LA STABILITE ET DE LA PLANEITE DE VOS SUPPORT OU SOLS RECEVANTS NOS EQUIPEMENTS, AUX DIFFERENTS EFFORTS ET CONTRAINTES AUQUELS ILS POURAIENT ETRE SOUMIS.</p> <p>CIVIL ENGINEERING WORKS ARE NOT INCLUDED IN PALAMATIC'S SCOPE OF SUPPLY. IT IS THE CLIENT'S RESPONSIBILITY TO ENSURE THE STABILITY, RESISTANCE AND FLATNESS OF THE STRUCTURES AND TERRAIN ON WHICH, PALAMATIC'S EQUIPMENT WILL BE MOUNTED. THESE STRUCTURES AND TERRAIN MUST BE ABLE TO WITHSTAND THE DIFFERENT LOADS AND CONSTRAINTS BROUGHT ON BY THESE EQUIPMENTS</p> |     | <p>CE PLAN EST LA PROPRIETE DE LA SOCIETE PALAMATIC - IL NE PEUT ETRE COPIE OU UTILISE SANS AUTORISATION</p> <p>THIS DRAWING IS THE PROPERTY OF THE COMPANY PALAMATIC - IT CANNOT BE COPIED OR USED WITHOUT AUTHORIZATION</p> |                            |
| <p>Rue de l'Ecotais<br/>Z.A. de la Croix Rouge<br/>35530 BRECE</p>   |     | <p>02 90 56 20 61<br/>CYRIL.PICHARD@PALAMATIC.FR</p>  |                            |
| <p>Designation / Name :<br/>VIDE SAC DEPOUSSIEREUR</p>   |     | <p>Dessiné par / Drawn by :<br/>PICHARD</p>   |                            |
| <p>Description :<br/>SACKTIP SDEP 1200</p>   |     | <p>Ref. Dossier / Project reference:</p>  |                            |
| 20-03-19   | A   | DIFFUSION   | CYP                        |
| DATE   | REV | OBSERVATION   | REVISER / REVISER          |
| Format : A3  |     | Echelle / Scale : 1:15  | N° Plan / Drawing number : |
|  |     | REV: A 2 / 3  |                            |

**SACKTIP OUVERTE / OPEN**

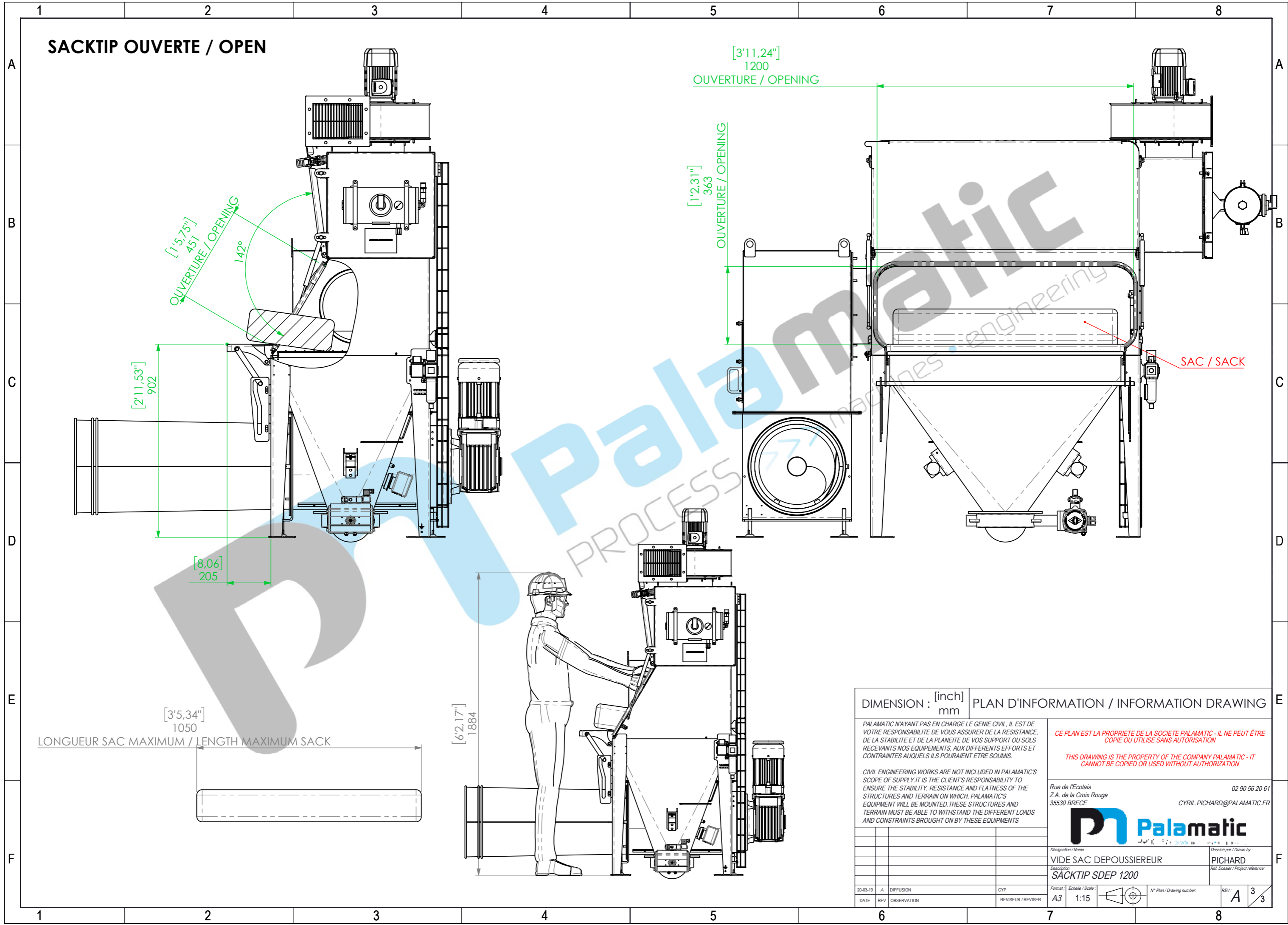

[3'5.34"]  
1050  
LONGUEUR SAC MAXIMUM / LENGTH MAXIMUM SACK

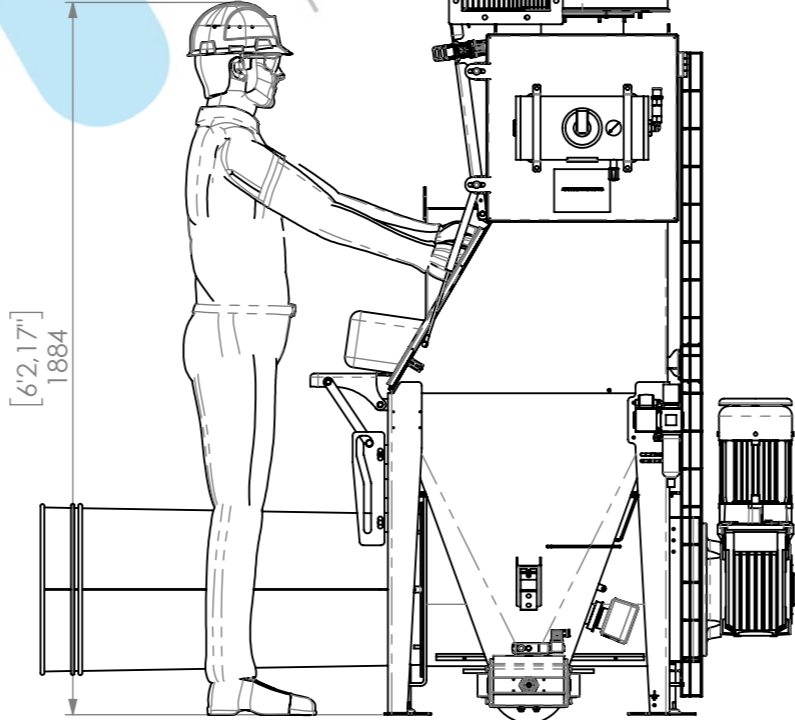

|  |     |   |                   |
|--|-----|---|-------------------|
| DIMENSION : [inch]<br>mm   |     | PLAN D'INFORMATION / INFORMATION DRAWING  |                   |
| <p>PALAMATIC N'AYANT PAS EN CHARGE LE GENIE CIVIL, IL EST DE VOTRE RESPONSABILITE DE VOUS ASSURER DE LA RESISTANCE, DE LA STABILITE ET DE LA PLANEITE DE VOS SUPPORT OU SOLS RECEVANTS NOS EQUIPEMENTS, AUX DIFFERENTS EFFORTS ET CONTRAINTES AUQUELS ILS POURAIENT ETRE SOUMIS.</p> <p>CIVIL ENGINEERING WORKS ARE NOT INCLUDED IN PALAMATIC'S SCOPE OF SUPPLY. IT IS THE CLIENT'S RESPONSIBILITY TO ENSURE THE STABILITY, RESISTANCE AND FLATNESS OF THE STRUCTURES AND TERRAIN ON WHICH, PALAMATIC'S EQUIPMENT WILL BE MOUNTED. THESE STRUCTURES AND TERRAIN MUST BE ABLE TO WITHSTAND THE DIFFERENT LOADS AND CONSTRAINTS BROUGHT ON BY THESE EQUIPMENTS</p> |     | <p><b>CE PLAN EST LA PROPRIETE DE LA SOCIETE PALAMATIC - IL NE PEUT ETRE COPIE OU UTILISE SANS AUTORISATION</b></p> <p><b>THIS DRAWING IS THE PROPERTY OF THE COMPANY PALAMATIC - IT CANNOT BE COPIED OR USED WITHOUT AUTHORIZATION</b></p> |                   |
| <p>Rue de l'Ecotais<br/>Z.A. de la Croix Rouge<br/>35530 BRECE</p>   |     | <p>02 90 56 20 61<br/>CYRIL.PICHARD@PALAMATIC.FR</p>  |                   |
| <p>Designation / Name :<br/><b>VIDE SAC DEPOUSSEUR</b></p>   |     | <p>Dessiné par / Drawn by :<br/><b>PICHARD</b></p>  |                   |
| <p>Description :<br/><b>SACKTIP SDEP 1200</b></p>  |     | <p>Ref. Dossier / Project reference:</p>  |                   |
| 20-03-19   | A   | DIFFUSION   | CYP               |
| DATE   | REV | OBSERVATION   | REVISER / REVISER |
| <p>Format / Echelle / Scale :<br/>A3 1:15</p>  |     | <p>N° Plan / Drawing number :<br/>REV: A 3 / 3</p>  |                   |